

Name: Adam Drake

Date: June 30, 2007 Event: ROAR 1/8th Nationals

City: St. Louis State: MO.

Track: Dirt Burners

Track Indoor Tight Smooth Hard Packed Blue Groove Wet Low Bite High Bite
 Conditions Outdoor Open Rough Loose/Loamy Dry Dusty Med Bite Other slick blue groove.

Front Suspension

Toe: 2 degrees out
 Ride Height: 27mm
 Camber: -1
 Caster: stock 20 degrees
 Sway Bar: 2.3mm
 Piston/Oil: 54 / 40 wt Losi oil
 Spring: Silver 4.4
 Limiter/Droop: Use droop screws to adjust shock length.
 Overall Shock Length: 95mm measure from center to center
 Steering Ackerman: Long
 Bump Steer: Down
 Camber Link: #2
 Shock Location: #2 / inside
 Front Diff Fluid: 5000 Losi
 Receiver Battery Type: Trinity 1400mah
 Center Diff Fluid: 7000 Losi

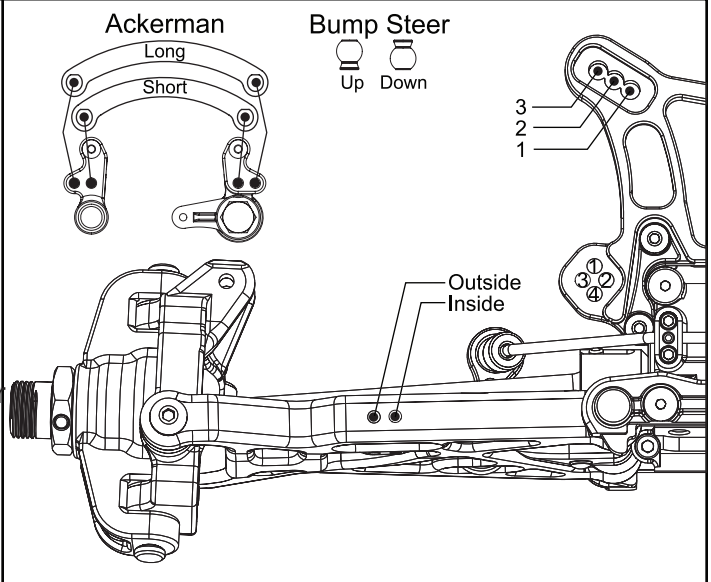

Notes: 8ight T servo saver spring. Alum. servo horn and servo saver top.

Rear Suspension

Toe: 3 degrees
 Anti-Squat: 3 degrees
 Ride Height: 28mm
 Camber: -2
 Rear Hub Spacing: All the way back. Spacers in front.
 Sway Bar: 2.3mm
 Piston/Oil: 56 / 25 wt Losi
 Spring: Green 3.1
 Limiter/Droop: Use droop screws to adjust shock length.
 Overall Shock Length: 106mm measure from center to center
 Camber Link: #4 / A
 Shock Location: #2 / inside
 Rear Diff Fluid: 2000 Losi

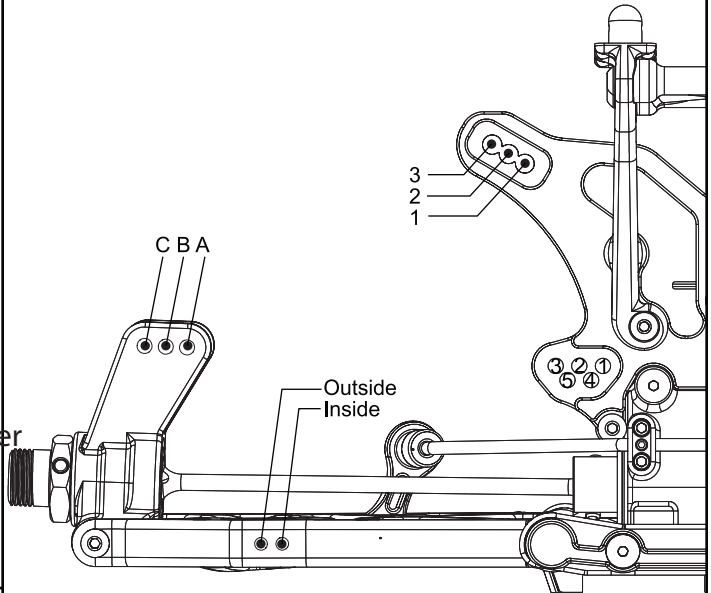

Notes: _____

Engine

Engine: Trinity / Drake .21 Fuel: Trinity Platinum 30%
 Glow Plug: Trinity / Drake hot Head Clearance: .023
 Pipe/Header: Trinity 40023 Gearing: 13/ 48

Clutch

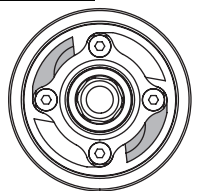

Clutch Shoes and Springs Info
2 alum. with silver springs
2 plastic with gold springs

Tires

Type	Compound	Insert
Front: <u>Taper Pin</u>	<u>Red</u>	<u>Team Losi</u>
Rear: <u>Taper-Pin</u>	<u>Red</u>	<u>Team Losi</u>

Notes: _____