



Setup Sheet

Track: Standard Setup The Dirt

Driver: Adam Drake

Date: January 2003

- | | | | |
|----------------------------------|---------------------------------|--------------------------------------|--------------------------------------|
| <input type="checkbox"/> Indoor | <input type="checkbox"/> Smooth | <input type="checkbox"/> Slippery | <input type="checkbox"/> Hard Packed |
| <input type="checkbox"/> Outdoor | <input type="checkbox"/> Rough | <input type="checkbox"/> High-Bite | <input type="checkbox"/> Loose/Loamy |
| <input type="checkbox"/> Tight | <input type="checkbox"/> Wet | <input type="checkbox"/> Blue-Groove | |
| <input type="checkbox"/> Open | <input type="checkbox"/> Dry | | |
- Weather: Sunny-90 deg

FRONT SUSPENSION

(Circle or Check the Appropriate Settings)

Toe In 1 °
 Out

Ride Height Arms Level

Camber - 1 °
 +

Caster Stock
 Other

Sway Bar No
 Yes size

of washers under steering / tie-rod ball studs
Spindle ball stud: 1
Bellcrank ball stud: 0

Servo Position: Front
Back

Front Shocks

Oil: 30 wt Losi

Piston: 56 Standard / Drilled

Spring: Red

Limiters: Inside- .120 Outside- 0

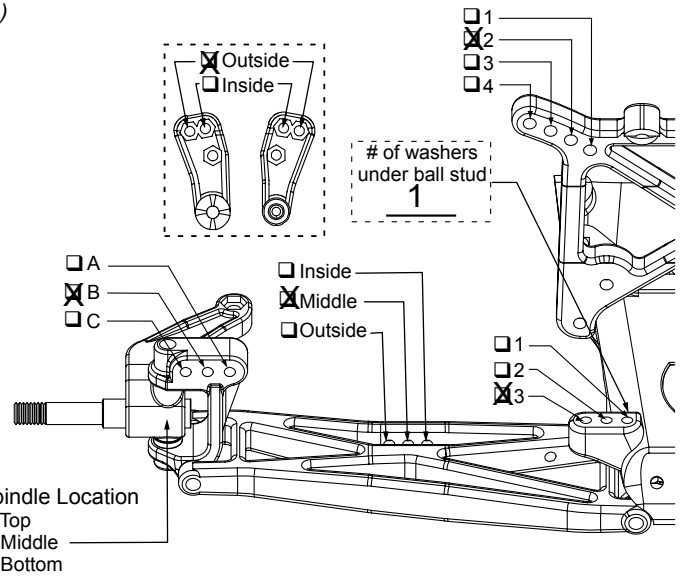

REAR SUSPENSION

Toe-In Inside 3 °
 Outside 1 °

Pivot Support 2 deg No Shim
 Shim Under Front Shim Under Rear > # of shims: _____

Ride Height Arms Level

Camber - 0 °
 +

Rear Hub Spacing Forward
 Center
 Rear

Sway Bar No
 Yes size

Drive Shafts Dogbones Aluminum
 CVDs Steel

Outdrives Steel
 Plastic

Rear Shocks

Oil: 40 wt Losi

Piston: 56 Standard / Drilled
Unthread shock ends 1 1/2 turns

Limiters: Inside- 0 Outside- 0

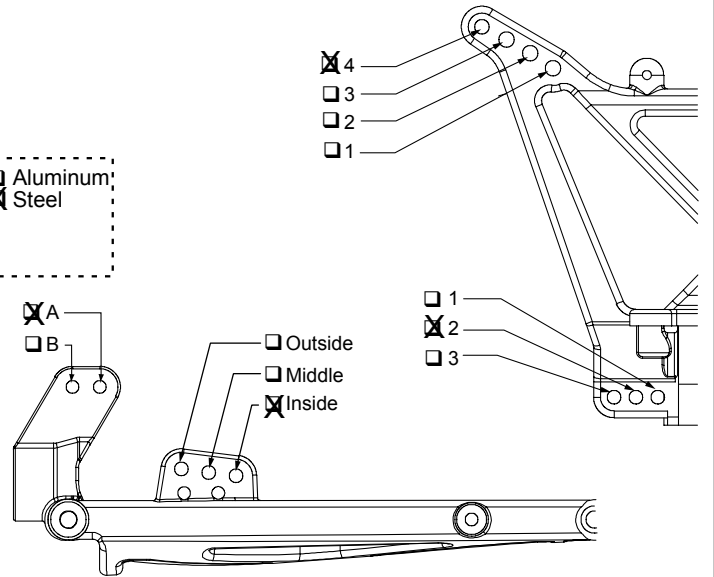

Tires

Front: Directionals

Compound Red

Foam Losi Firm

Body Stock

Rear: Step Pins

Compound Red

Foam Losi Firm

Spoiler yes no Size Stock

Engine: Trinity Picco

Fuel Type: Trinity Platinum Nitro%: 20

Clutch : Stock Other MIP

Carburetor Type: Slide valve / Rotary

Carb Restrictor: .170 .180 .190 None

Sprung Unsprung Leading Trailing

Glow Plug Type: MC-59

Muffler Type: Losi Drake

Engine Temp: 190-200

Manifold: Losi

Head Clearance: .020

Spur/Clutch Bell: 51 / 18

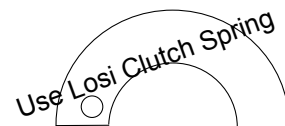

Shade where clutch was cut or lightened.

Notes: Use All Losi Graphite Parts. Trinity Alum front Pivot